

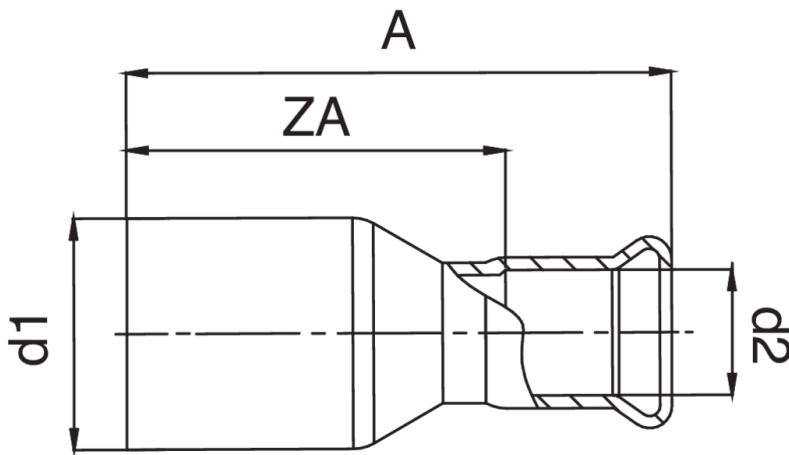

M/F reducer.



Specifiche tecniche



D1 X D2	BAG	MASTER BOX	CODICE	A	ZA
76,1 x 54	1	10	AMX243076054000	140	103
88,9 x 54	1	4	AMX243089054000	154	119
108 x 54	1	6	AMX243108054000	204	167

Applicazioni

