

4810

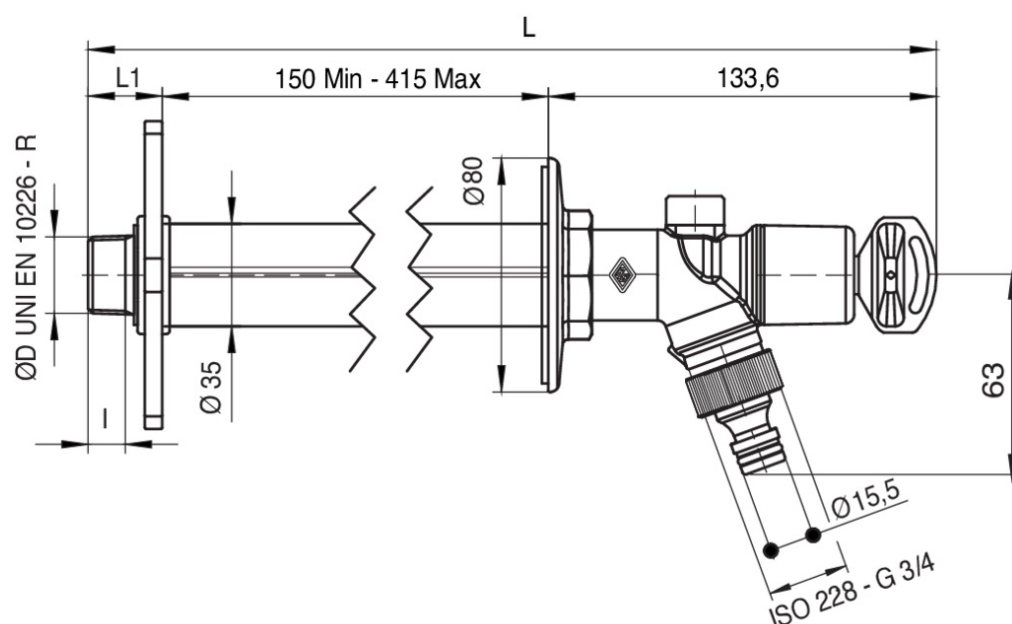

Rubinetto antigelo per esterni, con spurgo automatico, portagomma e chiavetta asportabile.

Specifiche tecniche



MISURA	DN	MASTER BOX	CODICE	ØP	I	L	L1	KV	PN	KG
1/2"	15	1	481004000	12	11,4	566,5	24	2,4	10	1,66
3/4"	20	1	481005000	12	12,7	568	25,5	2,4	10	1,67

Applicazioni



DRINKING
WATER