

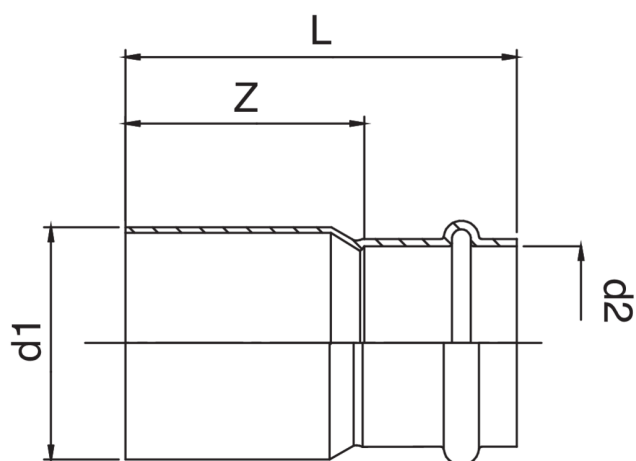

Manicotto di riduzione riduzione maschio-femmina.



Specifiche tecniche



D1 X D2	BAG	MASTER BOX	CODICE	L	Z
15 x 12	10	300	RK9243015012000	44	26
18 x 12	10	300	RK9243018012000	47	29
18 x 15	10	200	RK9243018015000	50	28
22 x 15	10	150	RK9243022015000	56	34
22 x 18	10	150	RK9243022018000	52	29

Applicazioni

