

300200

Filtre auto-nettoyant, maille 100 micron, avec écrou et union.

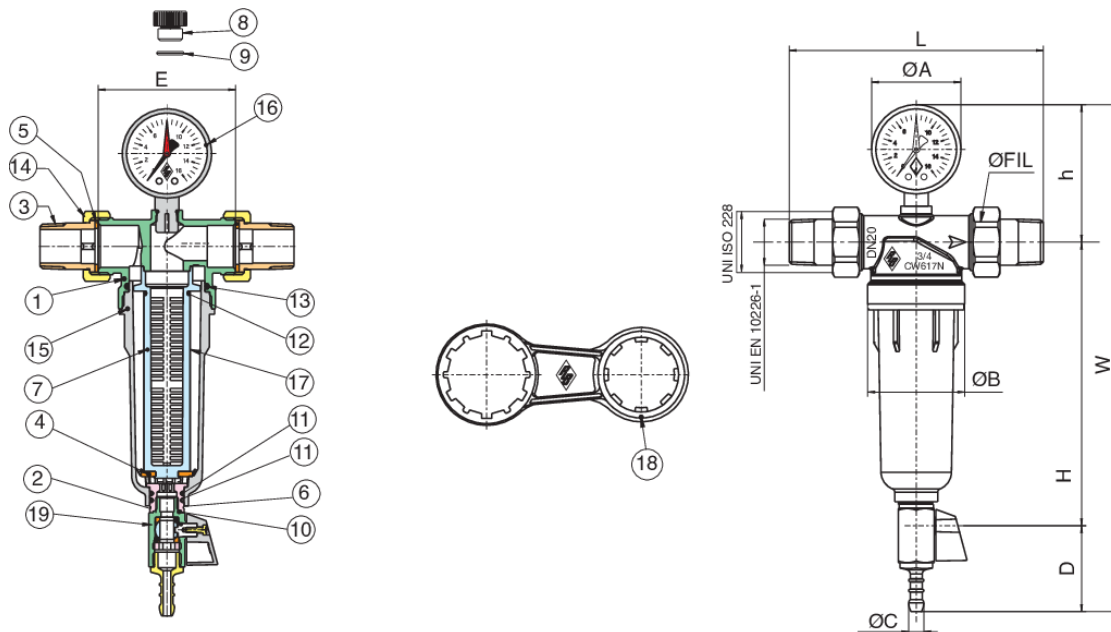

Spécifications techniques



POSITION	NOM DE LA PIÈCE	MATÉRIEL	N.° PIÈCES
1	CORPS	BRASS CW617N UNI EN 12165	1
2	SEEGER	HARMONIC STEEL	1
3	RACCORD	BRASS CW617N UNI EN 12165	2
4	JOINT PLAT	NBR	1
5	JOINT PLAT	GREEN ECOLOGICAL FIBER	2
6	RACCORD	BRASS CW614N UNI EN 12164	1
7	SUPPORT DU FILTRE	POM	1
8	CAPUCHON DU MANOMÈTRE	POM	1
9	O-RING	NBR	1
10	O-RING	EPDM	1
11	O-RING	EPDM	2
12	O-RING	EPDM	1
13	O-RING	EPDM	1
14	ECROU	BRASS CW617N UNI EN 12165	2
15	GODET	PSU	1
16	MANOMÈTRE	-	1
17	FILTRE À TOILE MÉTALLIQUE	STAINLESS STEEL AISI 304	1
18	CLÉ D' ENTRETIEN	PA6.6	1
19	ROBINET DE PURGE	-	1

TAILLE	DN	BOX	MASTER BOX	CODE	ØFIL	W	H	H	ØA	ØB	ØC	ØD	E	L	KV	PN	KG
1/2"	15	1	6	30020004	3/4"	289	77	162	52	56,5	9	50	80	140	4,4	16	0,80
3/4"	20	1	6	30020005	1"	295	80	165	52	56,5	9	50	80	148	7,5	16	0,90
1"	25	1	2	30020006	1"1/4	301	83,5	167	52	56,5	9	50	100	180	8,5	16	1,28

Nominal operating temperature: equal to 30 °C, in compliance with UNI EN 13443-1 standard - for different operating conditions, consult the technical staff of Rubinetteria Bresciane Bonomi.

Applications



DRINKING
WATER