

9368

Adapteur du siège euroconique/siège plat.

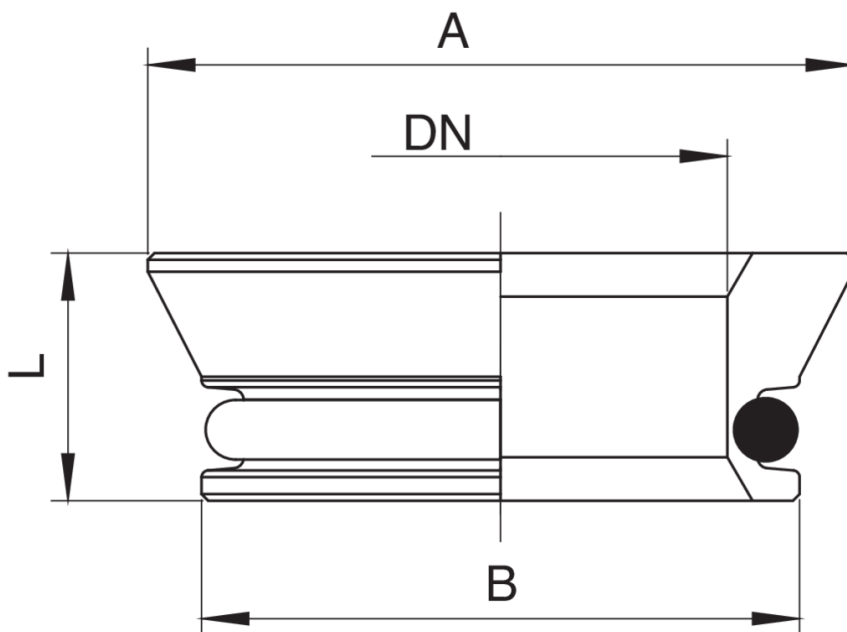

Spécifications techniques



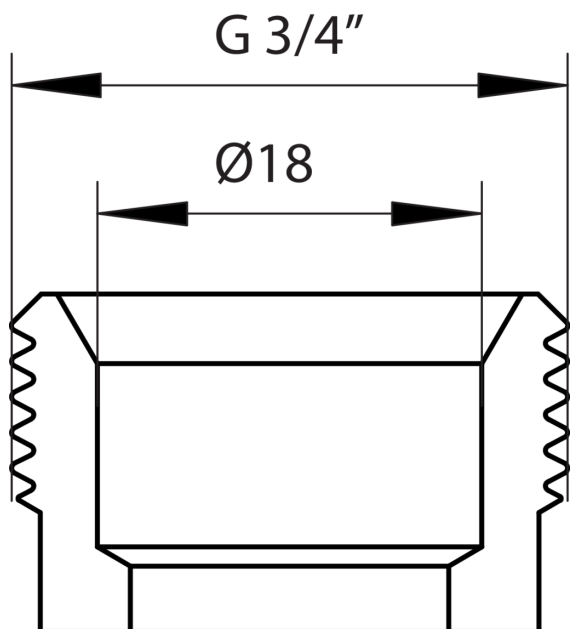

A X B	BOX	MASTER BOX	CODE	DN	L
3/4" x 18	20	160	9368050000	15	7,4

Applications



GAS