

9F91

Traverse en acier interaxe 110 mm, pour la liason des vannes avant et après compteur.

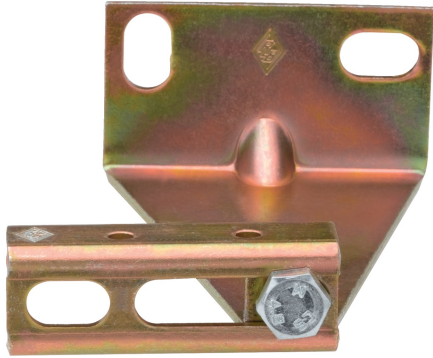

Spécifications techniques

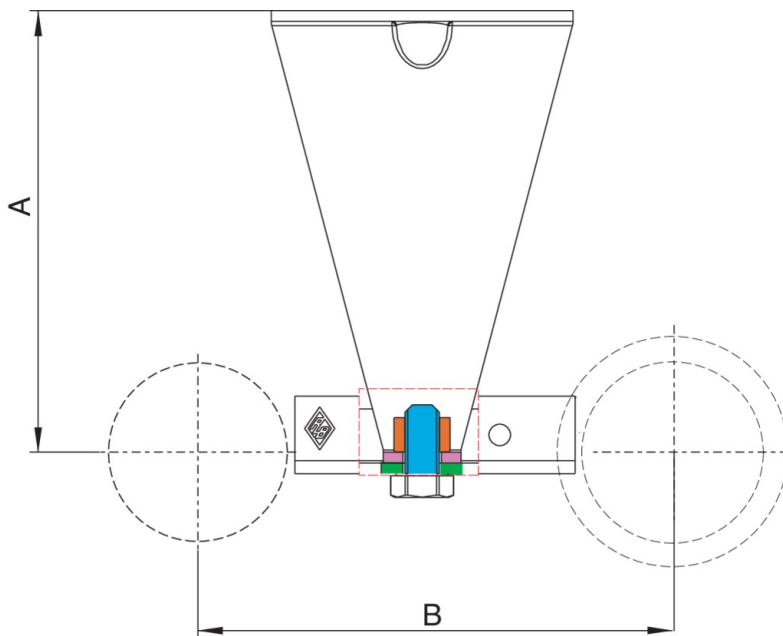

TAILLE	MASTER BOX	CODE	A	B
STANDARD	25	9F91000000	102,5	110

Applications



GAS