

Manchon coulissant F/F.

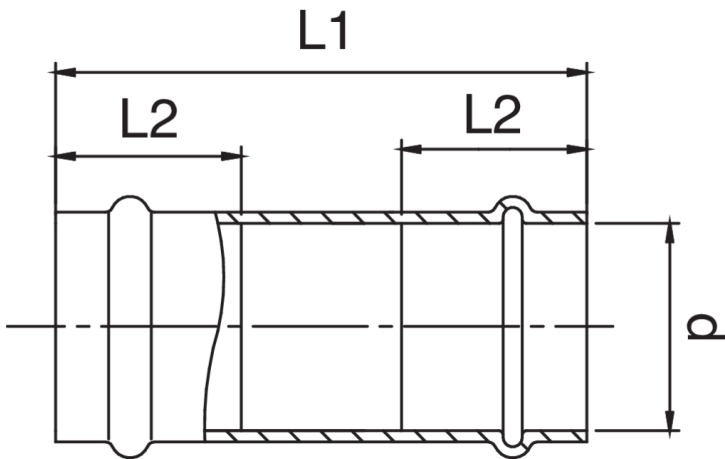

## Spécifications techniques



D	BAG	MASTER BOX	CODE	L1	L2
15	10	50	GX0271015015000	85	22
18	10	40	GX0271018018000	91	23
22	5	30	GX0271022022000	100	24
28	5	30	GX0271028028000	113	25
35	5	30	GX0271035035000	131	26
42	1	10	GX0271042042000	176	36
54	1	15	GX0271054054000	162	40

## Applications



GAS



COMPRESSED  
AIR



INDUSTRIAL