



Courbe 60° M/F.

NEW



Spécifications techniques

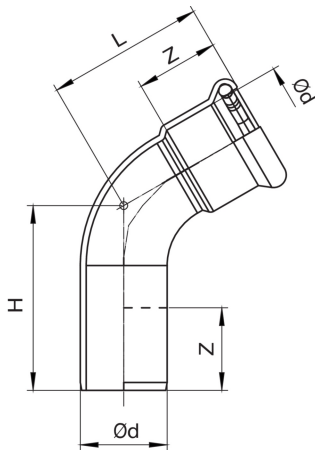

D	BAG	MASTER BOX	CODE	L	H	Z
15	10	250	MX0048015015000	34	40,5	19
18	10	250	MX0048018018000	36	42,5	19,5
22	5	120	MX0048022022000	42,5	49,5	21
28	5	60	MX0048028028000	46,5	54	22
35	5	50	MX0048035035000	69	75,5	27
42	2	24	MX0048042042000	88,5	95	30
54	2	16	MX0048054054000	112,5	119	35

Applications



DRINKING
WATER



HEATING



HVAC



COMPRESSED
AIR



FIREFIGHTING



MARINE



STEAM



SOLAR



INDUSTRIAL