

Manguito con remante H/H.

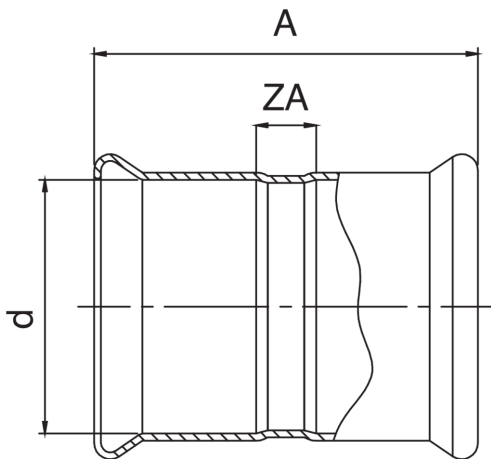

## Especificaciones técnicas



D	BAG	MASTER BOX	CÓDIGO	A	ZA
76,1	1	5	AX0270076076000	152	50
88,9	1	5	AX0270089089000	175	54
108	1	5	AX0270108108000	204	66

## Aplicaciones

