

## 595022

Válvula de paro por descarga con asiento de hermeticidad.

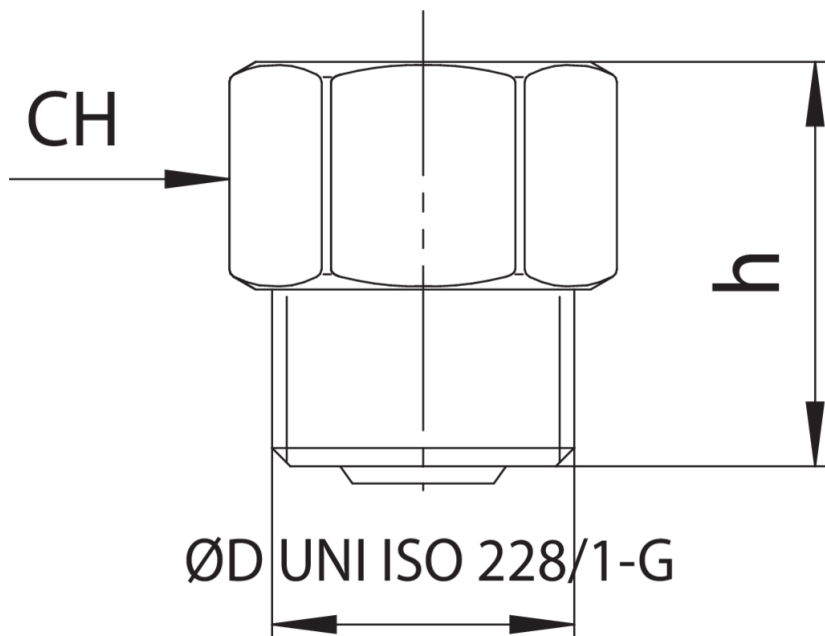

### Especificaciones técnicas



TRATTAMENTO - TREATMENT	MISURA - SIZE	BOX	MASTER BOX	CÓDIGO	H	CH
Nichelato - Nickel plated	3/8"	50	200	59502203	21	19
Nichelato - Nickel plated	1/2"	50	200	59502204	21	23

# Aplicaciones



DRINKING WATER



HEATING



HVAC



COMPRESSED AIR



INDUSTRIAL



MARINE