

**9368**

Adaptador eurocono/asiento plano.

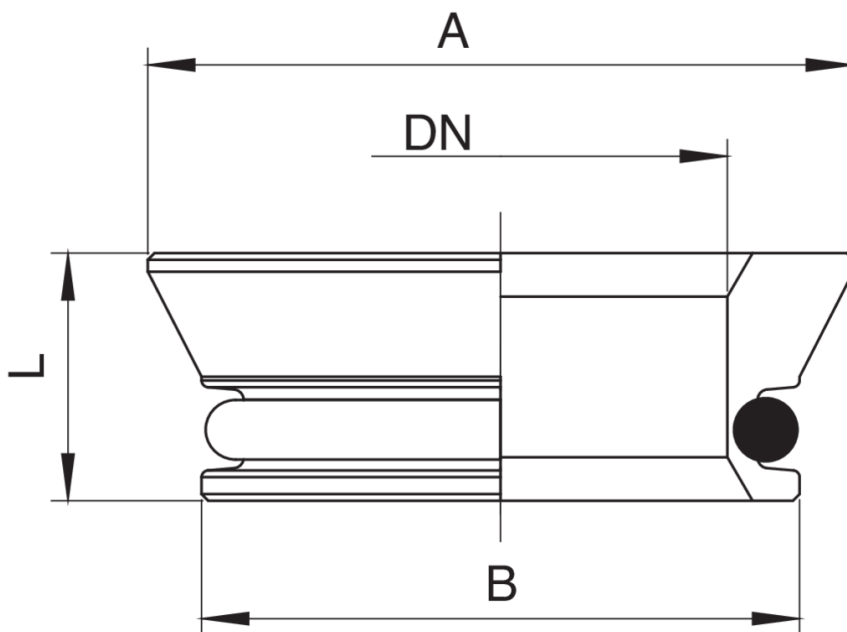

## Especificaciones técnicas



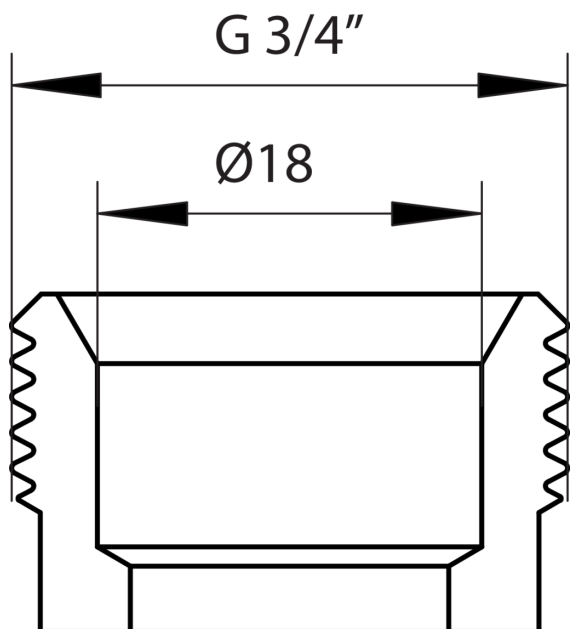

A X B	BOX	MASTER BOX	CÓDIGO	DN	L
3/4" x 18	20	160	9368050000	15	7,4

## Aplicaciones



GAS