

Manguito con remante H/H.

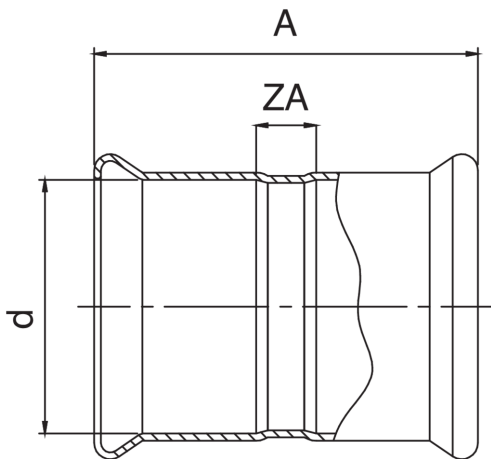

Especificaciones técnicas



| D | BAG | MASTER BOX | CÓDIGO | A | ZA |
|----|-----|------------|-----------------|----|----|
| 15 | 10 | 150 | MX0270015015000 | 48 | 9 |
| 18 | 10 | 100 | MX0270018018000 | 48 | 9 |
| 22 | 5 | 30 | MX0270022022000 | 50 | 5 |
| 28 | 5 | 40 | MX0270028028000 | 54 | 9 |
| 35 | 5 | 35 | MX0270035035000 | 62 | 11 |
| 42 | 1 | 25 | MX0270042042000 | 73 | 14 |
| 54 | 1 | 15 | MX0270054054000 | 85 | 16 |

Aplicaciones



DRINKING
WATER



HEATING



HVAC



COMPRESSED
AIR



FIREFIGHTING



MARINE



STEAM



SOLAR



INDUSTRIAL