

Manguito mixto H/rosca hembra de bronce.

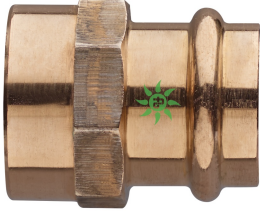

Especificaciones técnicas

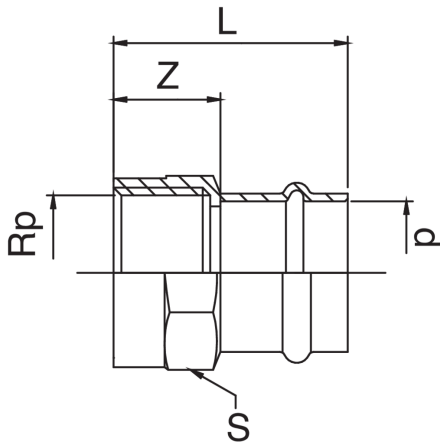

D X Rp	BAG	MASTER BOX	CÓDIGO	L	S	Z
15 x 1/2"	10	200	HT8270A12015000	40	25	3
18 x 1/2"	10	150	HT8270A12018000	41	27	3
18 x 3/4"	10	100	HT8270A34018000	44	31	4
22 x 3/4"	10	100	HT8270A34022000	46	32	5
22 x 1"	5	80	HT8270B01022000	47	38	4
28 x 3/4"	5	60	HT8270A34028000	48	38	8

Aplicaciones



SOLAR



STEAM



COMPRESSED
AIR



INDUSTRIAL