

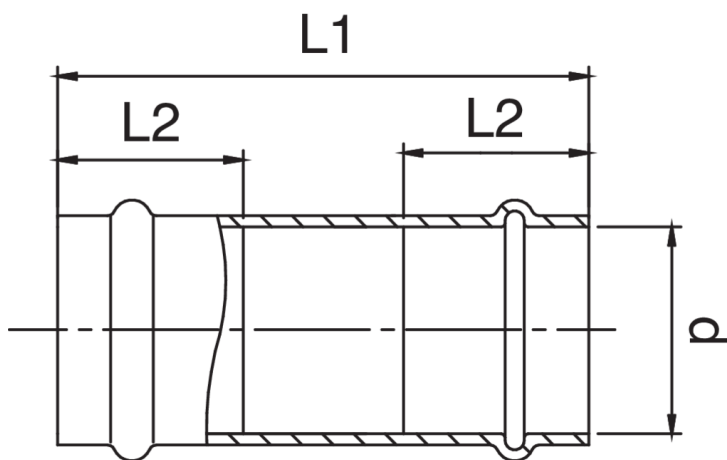

Especificaciones técnicas



D	BAG	MASTER BOX	CÓDIGO	L1	L2
15	10	50	ZX0271015015000	85	22
18	10	40	ZX0271018018000	91	23
22	5	30	ZX0271022022000	100	24
28	5	30	ZX0271028028000	113	25
35	5	30	ZX0271035035000	131	26
42	1	10	ZX0271042042000	176	36
54	1	15	ZX0271054054000	162	40

Aplicaciones



DRINKING
WATER



HEATING



HVAC



COMPRESSED
AIR



FIREFIGHTING



MARINE



STEAM



SOLAR



INDUSTRIAL