

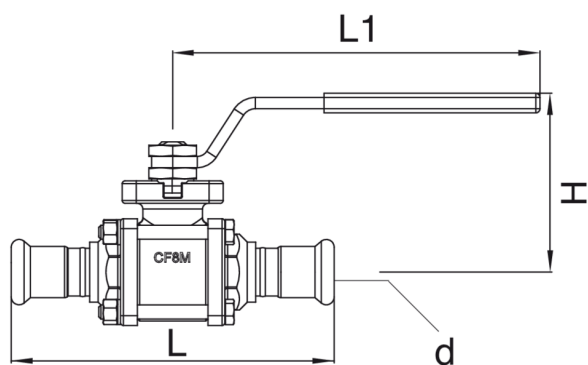

3-piece stainless steel AISI 316-CF8M ball valve with CuNi connections.

Technical specifications



D	BAG	MASTER BOX	CODE	L	H	L1
15	6	24	5N900015	116	64	131
18	-	-	5N900018	-	-	-
22	2	8	5N900022	137	68,5	131
28	2	4	5N900028	156	78	174
35	2	4	5N900035	184	82,5	174
42	-	2	5N900042	198	100	250,5
54	-	2	5N900054	230	107	250,5
76,1	-	1	5N900076	295	126	321
88,9	-	1	5N900088	346	137,5	321
108	-	1	5N900108	415	156,5	381,5

Applications



MARINE