

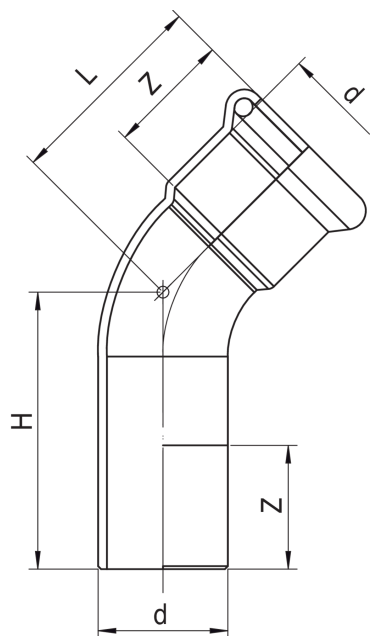

M/F 45° elbow.

Technical specifications



D	BAG	MASTER BOX	CODE	L	H	Z
15	10	250	5N150015	31	43	19
18	10	250	5N150018	32	45	19,5
22	5	120	5N150022	38	47	21
28	5	60	5N150028	41	50	22
35	5	40	5N150035	52	58,5	27
42	2	24	5N150042	66,3	72,8	30
54	2	12	5N150054	86,3	93,3	35
76,1	1	5	5N150076	103	109	54
88,9	1	3	5N150088	116	124	61
108	1	2	5N1500108	153	161	76

Applications



MARINE