

**545000**

**PATENTED**

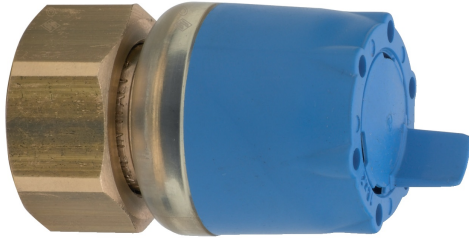

2 pieces straight fitting flat seals.

## Technical specifications

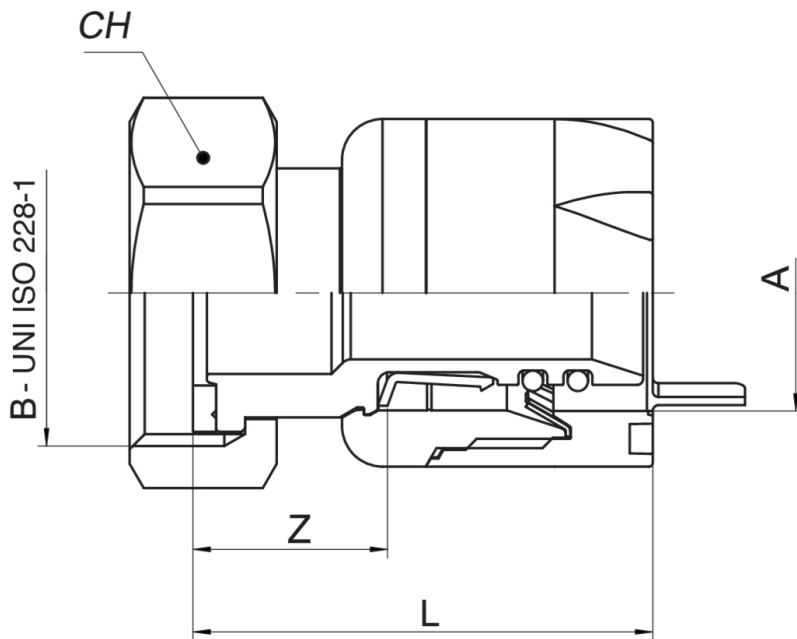

A X B	SP	BAG	BOX	MASTER BOX	CODE	CH	L	Z
16 x 1/2"	2	1	60	240	5450001604	24	38,5	15,5
20 x 3/4"	2	1	50	200	5450002005	30	40	17

## Applications



DRINKING  
WATER



HEATING



HVAC



COMPRESSED  
AIR



INDUSTRIAL



MARINE

