

## BUBBLE-SFER

### 2U20

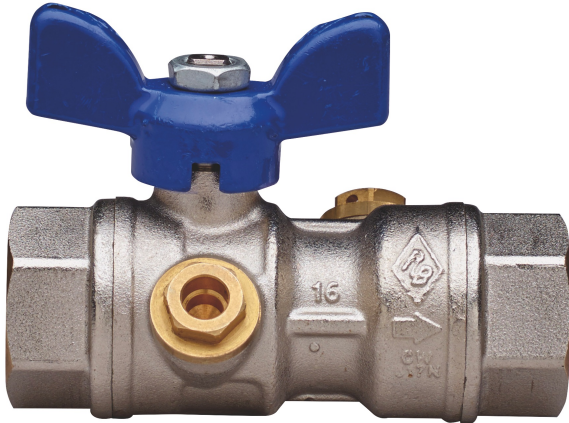

Water full bore ball valve with meter's exit, thread F/F, **large** check valve incorporated, pressure measurement connection aluminium butterfly handle and ball with automatic rinse system.

## Technical specifications

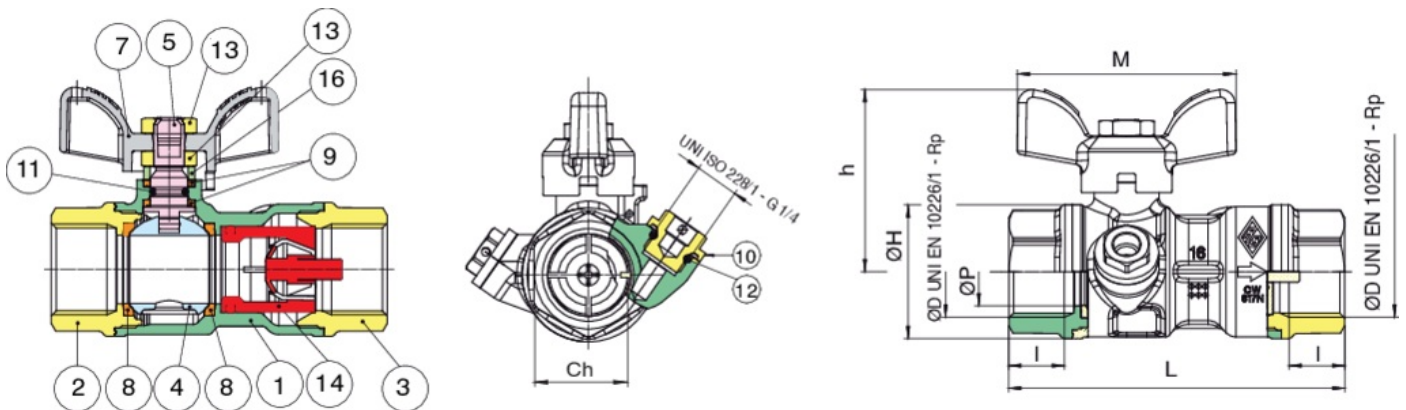

POSITION	PART NAME	MATERIAL	N.° PIECES
1	BODY	BRASS CW617N UNI EN 12420	1
2	END CONNECTION	BRASS CW617N UNI EN 12420	1
3	END CONNECTION	BRASS CW617N UNI EN 12420	1
4	BALL	BRASS CW617N UNI EN 12420	1
5	STEM	BRASS CW614N UNI EN 12164	1
6	PACKING GLAND	BRASS CW614N UNI EN 12164	1
7	T-HANDLE	ALUMINIUM EN-AC 46100	1
8	BALL SEAT	PTFE	2
9	STEM SEAL/THRUST WASHER	PTFE	2
10	CAP	BRASS CW614N UNI EN 12164	2
11	O-RING	NBR	1
12	O-RING	NBR	2
13	NUT	STEEL CL 04	2
14	CHECK VALVE	POM	1

SIZE	BOX	MASTER BOX	CODE	ØP	I	CH	ØH	L	H	M	KV	PN	KG
1/2"	10	40	2U20040000	15	15	27	33	86	41,5	50	9	64	0,36
3/4"	10	40	2U20050000	20	16,3	32	39	98,5	53	64	14	64	0,50

## Applications



DRINKING  
WATER



MULTIUTILITY ONLY