

BUBBLE-SFER

2U45

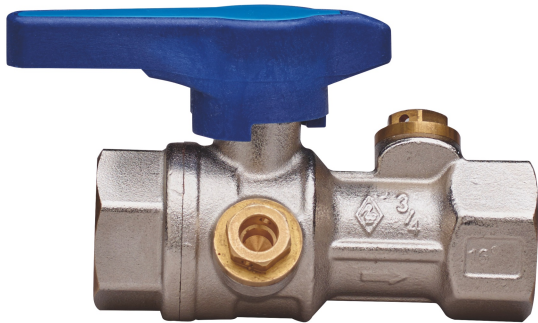

Water full bore ball valve with meter's exit, thread F/F, check valve incorporated, pressure measurement connection, technopolymer handle and ball with automatic rinse system.

Technical specifications

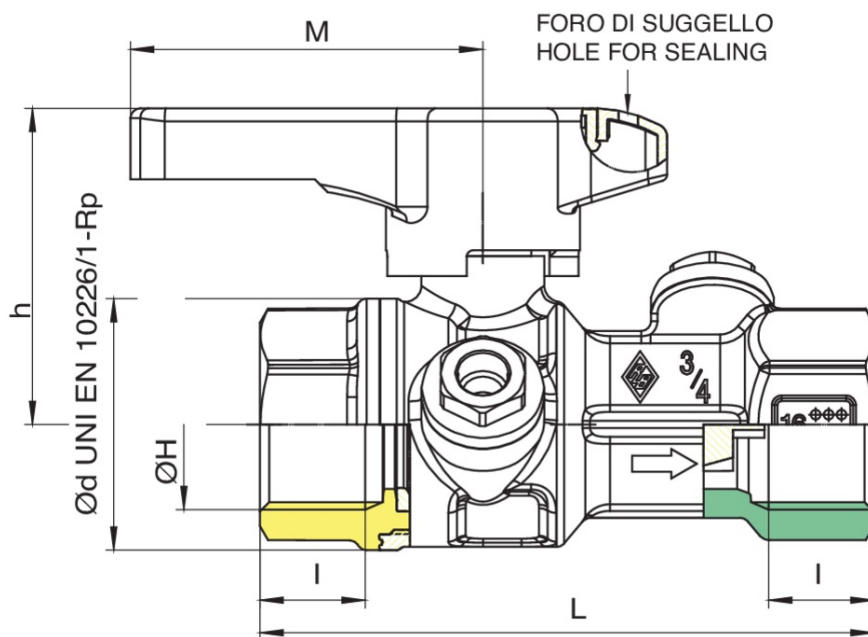

SIZE	BOX	MASTER BOX	CODE	I	ØH	L	M	H	KV	PN	KG
1/2"	10	40	2U45040000	15	33	80,5	54,5	41,5	4,6	64	0,31
3/4"	10	40	2U45050000	16,3	39	95	54,5	49	8,8	64	0,46
1"	10	20	2U45060000	19,1	49	110,5	54,5	53	15	64	0,68

Applications



DRINKING
WATER



MULTIUTILITY ONLY

