

BUBBLE-SFER

2U25

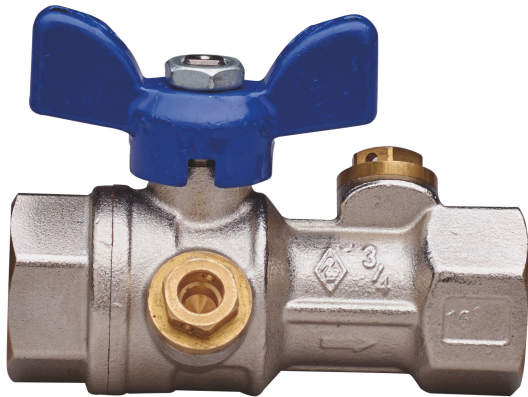

Water full bore ball valve with meter's exit, thread F/F, check valve incorporated, pressure measurement connection aluminium butterfly handle and ball with automatic rinse system.

Technical specifications

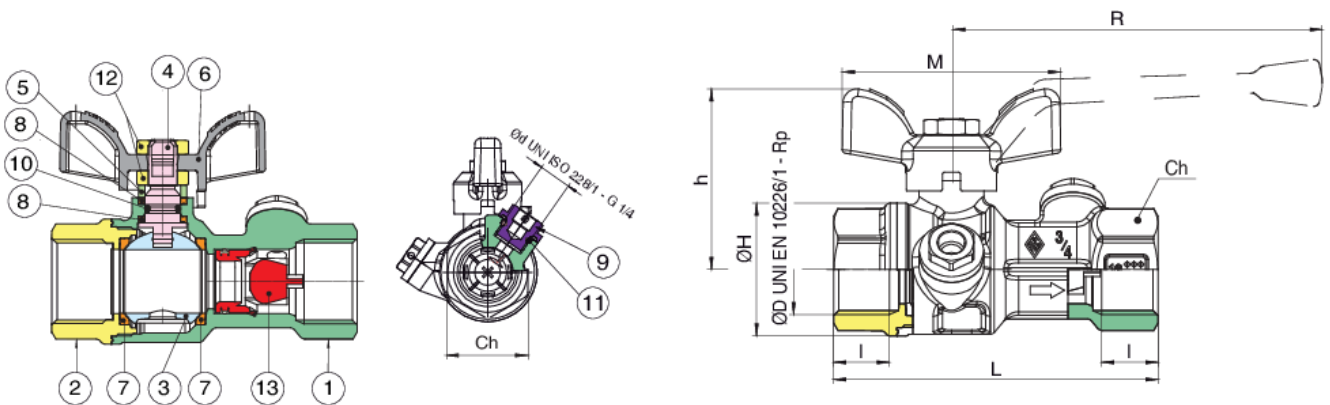

POSITION	PART NAME	MATERIAL	N.° PIECES
1	BODY	BRASS CW617N UNI EN 12420	1
2	END CONNECTION	BRASS CW617N UNI EN 12420	1
3	BALL	BRASS CW617N UNI EN 12420	1
4	STEM	BRASS CW614N UNI EN 12164	1
5	PACKING GLAND	BRASS CW614N UNI EN 12164	1
6	T-HANDLE	ALUMINIUM EN-AC 46100	1
7	BALL SEAT	PTFE	2
8	STEM SEAL/THRUST WASHER	PTFE	2
9	CAP	BRASS CW614N UNI EN 12164	2
10	O-RING	NBR	1
11	O-RING	NBR	2
12	NUT	STEEL CL 04	2
13	CHECK VALVE	POM	1

SIZE	DN	BOX	MASTER BOX	CODE	ØP	I	CH	ØH	L	H	M	R	KV	PN	KG
1/2"	15	10	40	2U25040000	15	15	27	33	80,5	41,5	50	-	4,6	64	0,30
3/4"	20	10	40	2U25050000	20	16,3	32	39	95	53	64	-	8,8	64	0,46
1"	25	10	20	2U25060000	25	19,1	38	49	110,5	57	64	-	15	64	0,69
1"1/4*	32	6	12	2U25070000	32	21,4	48	59	126	79,5	-	160	22	50	1,08
1"1/2*	40	4	8	2U25080000	40	21,4	54	73	143,5	86	-	160	32	40	1,56
2**	50	2	4	2U25100000	50	25,7	67	87	175	104	-	170	55	40	2,47

*Version with aluminium handle.

Applications



DRINKING
WATER



MULTIUTILITY ONLY