

## 4810

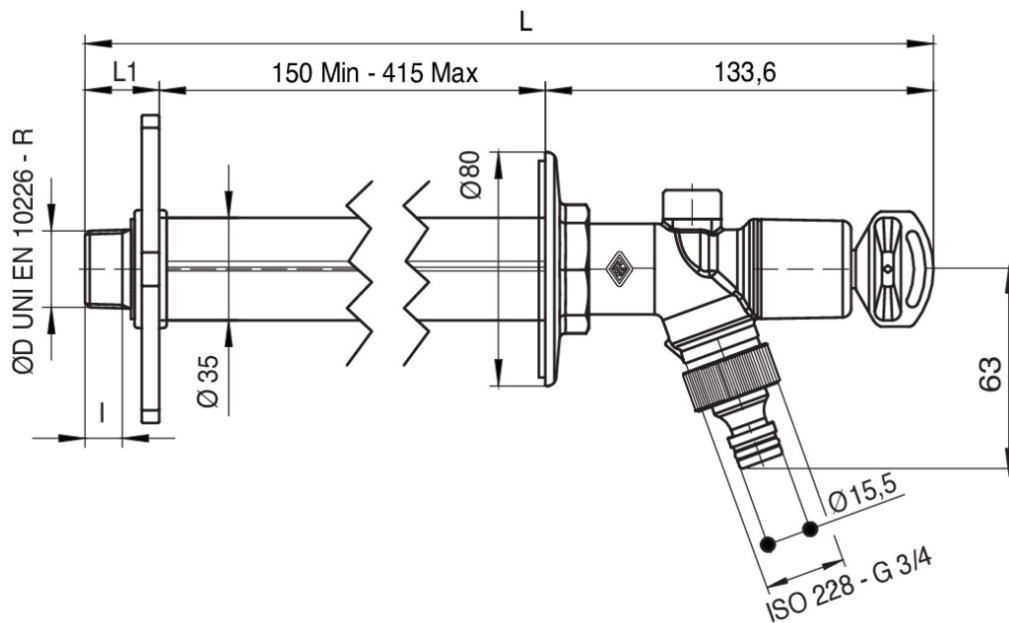

Anti-freeze faucet for outdoor applications, with vacuum breaker valve, hose tail connection and removable key.

### Technical specifications



| SIZE | DN | MASTER BOX | CODE      | ØP | I    | L     | L1   | KV  | PN | KG   |
|------|----|------------|-----------|----|------|-------|------|-----|----|------|
| 1/2" | 15 | 1          | 481004000 | 12 | 11,4 | 566,5 | 24   | 2,4 | 10 | 1,66 |
| 3/4" | 20 | 1          | 481005000 | 12 | 12,7 | 568   | 25,5 | 2,4 | 10 | 1,67 |

### Applications



DRINKING  
WATER