

4491

Built-in full bore ball valve, F/F threaded, with extractable ball and cover.

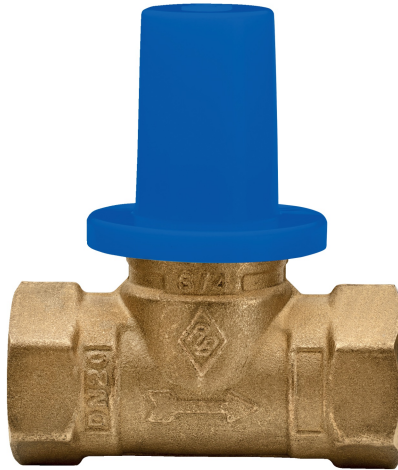

NEW

Technical specifications

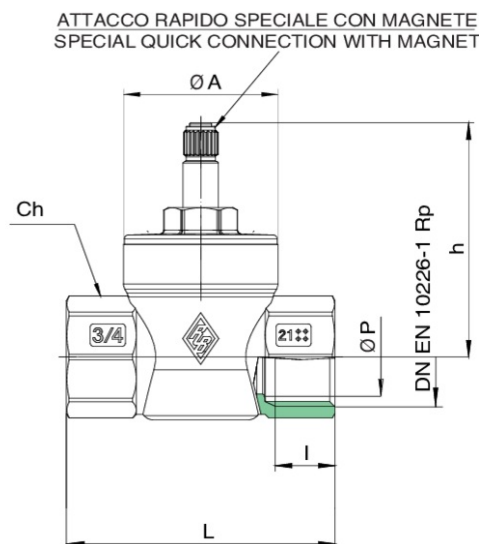
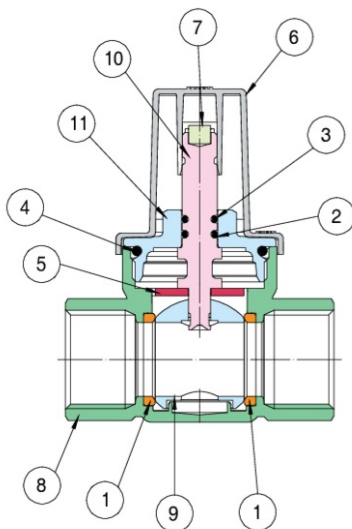

| POSITION | PART NAME | MATERIAL | N.° PIECES |
|----------|--------------------|--------------------------------------|------------|
| 1 | BALL SEAT | PTFE | 2 |
| 2 | O-RING | NBR | 1 |
| 3 | O-RING | FKM | 1 |
| 4 | O-RING | NBR | 1 |
| 5 | WASHER | STAINLESS STEEL AISI 304 | 1 |
| 6 | COVER | POLY PROPYLENE | 1 |
| 7 | MAGNET | NEODIMIO | 1 |
| 8 | BODY | BRASS CW617N UNI EN 12420 | 1 |
| 9 | BALL | BRASS CW617 UNI EN 12420 | 1 |
| 10 | STEM | BRASS CW614N UNI EN12164-UNI EN12168 | 1 |
| 11 | STEM RETAINING NUT | BRASS CW617 UNI EN 12420 | 1 |

| SIZE | DN | BOX | MASTER BOX | CODE | ØP | I | L | CH | H | ØA | KV | PN | KG |
|------|----|-----|------------|------------|----|------|------|----|------|----|------|----|-------|
| 1/2" | 15 | 10 | 40 | 4491040000 | 15 | 15 | 63,5 | 26 | 58,5 | 32 | 16,3 | 30 | 0,245 |
| 3/4" | 20 | 10 | 20 | 4491050000 | 20 | 16,3 | 73 | 31 | 63,5 | 42 | 29,5 | 30 | 0,406 |

Temperature range: -20°C +90°C.

Applications



DRINKING
WATER



HEATING



HVAC



COMPRESSED
AIR



INDUSTRIAL



MARINE