

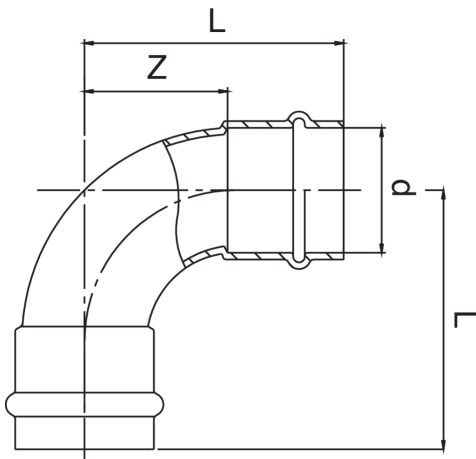

## Technical specifications



D	BAG	MASTER BOX	CODE	L	Z
15	10	100	ZX0002015015000	40	18
18	10	100	ZX0002018018000	45	22
22	5	50	ZX0002022022000	51	27
28	5	30	ZX0002028028000	59	34
35	5	25	ZX0002035035000	68	42
42	1	10	ZX0002042042000	87	51
54	1	7	ZX0002054054000	105	65

## Applications



DRINKING  
WATER



HEATING



HVAC



COMPRESSED  
AIR



FIREFIGHTING



MARINE



STEAM



SOLAR



INDUSTRIAL