

T-Stück IG.

## Technische Spezifikationen

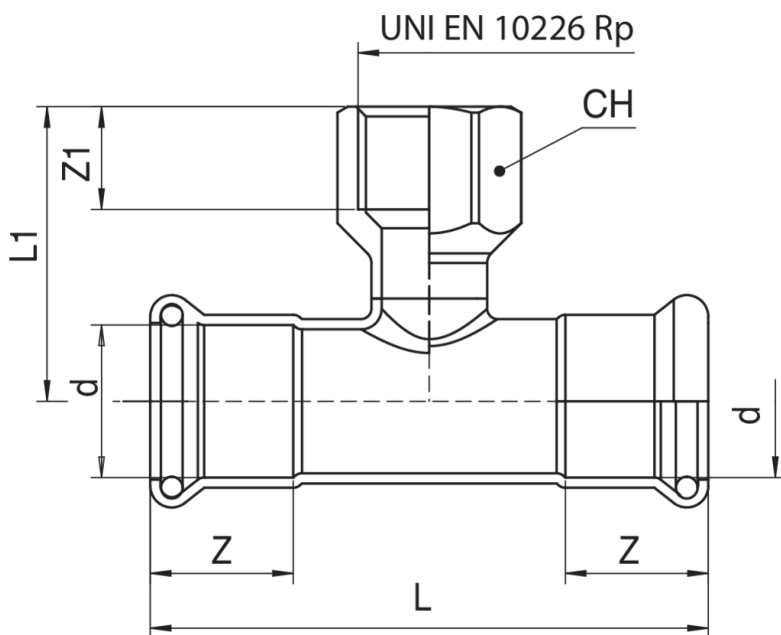

<b>D X RP X D</b>	<b>BAG</b>	<b>MASTER BOX</b>	<b>CODE</b>	<b>L</b>	<b>L1</b>	<b>Z</b>	<b>Z1</b>	<b>CH</b>
15 x 1/2" x 15	10	160	5N3100150415	67	39	19	15	24
18 x 1/2" x 18	10	160	5N3100180418	70	41	19,5	15	24
22 x 1/2" x 22	5	100	5N3100220422	82	43	21	15	24
22 x 3/4" x 22	5	75	5N3100220522	82	43	21	16,3	30
28 x 1/2" x 28	5	60	5N3100280428	90	46	22	15	24
28 x 3/4" x 28	5	60	5N3100280528	90	46	22	16	30
35 x 1/2" x 35	5	40	5N3100350435	106	47,5	27	15	24
35 x 3/4" x 35	5	40	5N3100350535	106	47,5	27	16,3	30
42 x 1/2" x 42	2	30	5N3100420442	118	51	30	15	24
42 x 3/4" x 42	2	24	5N3100420542	118	51	30	16,3	30
54 x 1/2" x 54	2	16	5N3100540454	144	58	35	15	24
54 x 3/4" x 54	2	16	5N3100540554	144	58	35	16,3	30
76,1 x 3/4" x 76,1	1	6	5N3100760576	232	70	54	16,3	30
88,9 x 3/4" x 88,9	1	3	5N3100880588	243	76	61	16,3	30
108 x 3/4" x 108	1	2	5N310010805108	310	90	76	16,3	30

## Anwendungen



MARINE