

505200

PATENTED

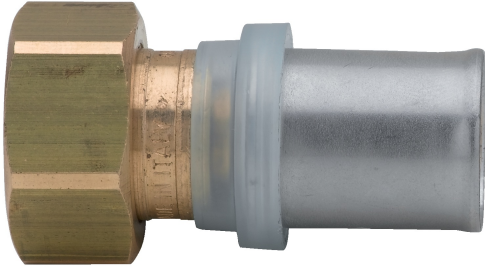

Anschlusspressverschraubung mit Kegelring 1/2".



Technische Spezifikationen

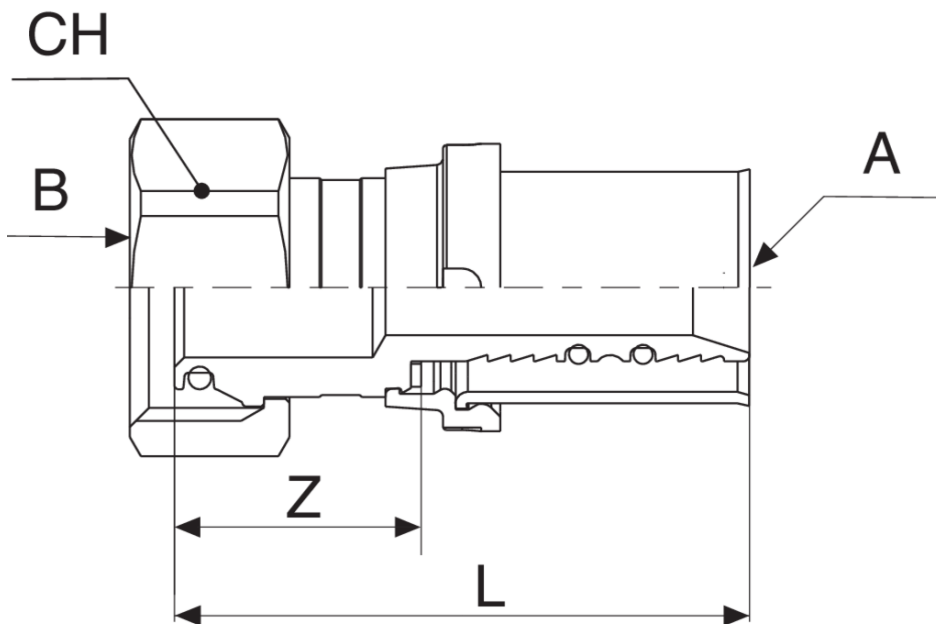

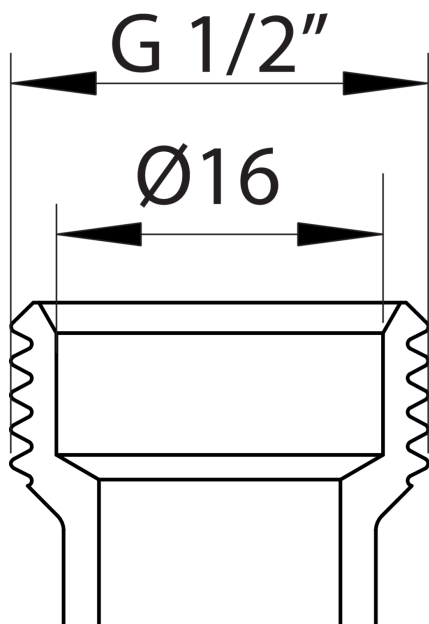

A x B	SP	BAG	BOX	MASTER BOX	CODE	CH	L	Z
14 x 1/2"	2	5	60	240	5052001404	24	45	19,5
16 x 1/2"	2	5	60	240	5052001604	24	45	19,5
20 x 1/2"	2	5	60	240	5052002004	24	46	20,3

Anwendungen



DRINKING
WATER



HEATING



HVAC



COMPRESSED
AIR



INDUSTRIAL



MARINE