



**540000**

**PATENTED**

Übergangsstück mit Aussengewinde.

## Technische Spezifikationen

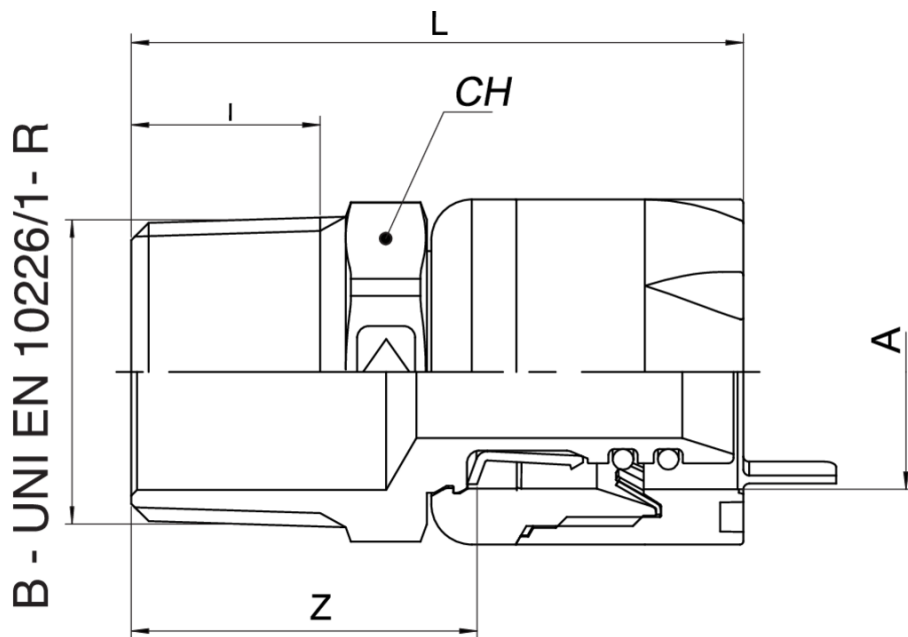

A X B	SP	BAG	BOX	MASTER BOX	CODE	I	CH	L	Z
16 x 1/2"	2	1	40	160	5400001604	15	22	51,5	28,5
20 x 1/2"	2	1	40	160	5400002004	15	22	51,5	28,5
20 x 3/4"	2	1	40	160	5400002005	16,3	27	53	30
26 x 3/4"	3	1	30	120	5400002605	16,3	27	55	30
26 x 1"	3	1	25	100	5400002606	19,1	34	60	35

## Anwendungen



DRINKING  
WATER



HEATING



HVAC



COMPRESSED  
AIR



INDUSTRIAL



MARINE

