

BUBBLE-SFER

2096

PATENTED

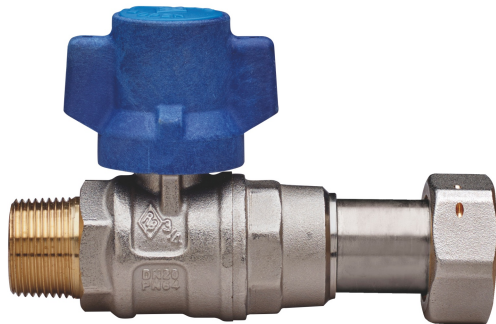

Kugelhahn für den Eingang des Trinkwasserzählers, voller Durchgang, einerseits Aussengewinde, andererseits , mit **narrensicherem** Flügelgriff und Kugel mit automatischer Hinterspülung.



MULTILITY ONLY

Technische Spezifikationen

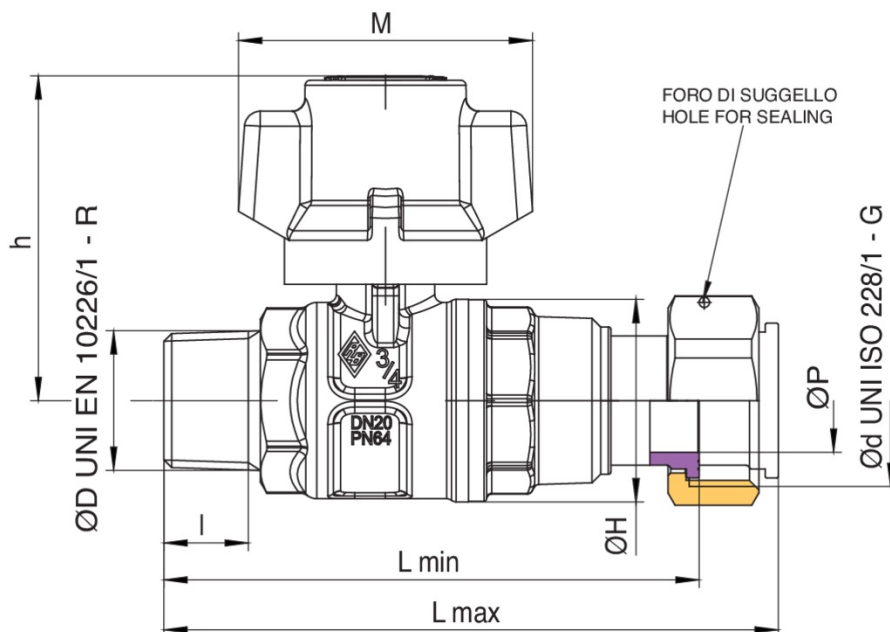

ØD X ØD	BOX	MASTER BOX	CODE	ØP	I	ØH	L MIN	L MAX	H	M	KV	PN	KG
1/2" x 3/4"	10	40	2096260000	15	15	33	91,5	105	55,5	57	16,3	64	0,34
3/4" x 1"	10	20	2096580000	20	16,3	39	103	118,5	66,5	57	29,5	64	0,53

Anwendungen



DRINKING
WATER



MULTIUTILITY ONLY