

## BUBBLE-SFER

2091

PATENTED

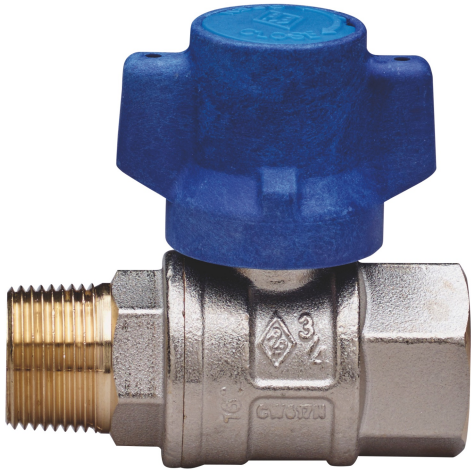

Kugelhahn für Trinkwasser, voller Durchgang, einerseits Innengewinde, andererseits Aussengewinde, mit **narrensicherem** Flügelgriff und Kugel mit automatischer Hinterspülung.



### Technische Spezifikationen

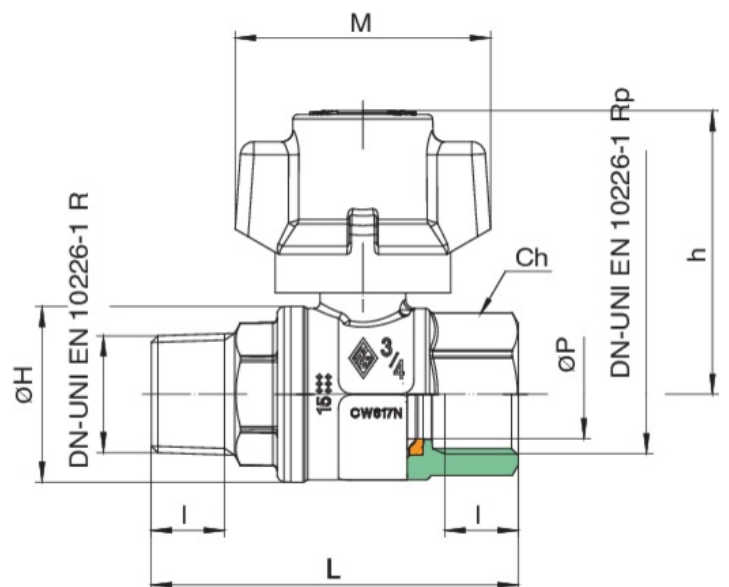
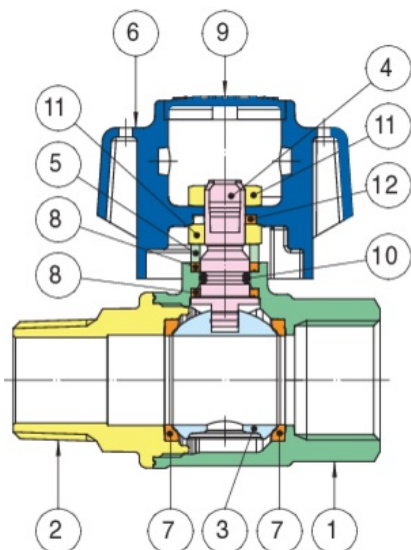

POSITION	TEILNAME	MATERIAL	NR. STÜCK
1	GEHÄUSE	BRASS CW617N UNI EN 12420	1
2	MUFFE	BRASS CW617N UNI EN 12420	1
3	KUGEL	BRASS CW617N UNI EN 12420	1
4	SPINDEL	BRASS CW614N UNI EN 12164	1
5	VORSPANNUNG	BRASS CW614N UNI EN 12164	1
6	GRIFF	PA6	1
7	KUGELDICHTUNG	PTFE	2
8	STOßHEMMEDE DICHTUNG	PTFE	2
9	KAPPE	PE	1
10	O-RING	NBR	1
11	MUTTER	STEEL CL 04	2
12	SCHEIBE	STEEL	1

GRÖSSE	DN	BOX	MASTER BOX	CODE	ØP	I	L	ØH	CH	M	H	KV	PN	KG
1/2"	15	15	60	2091040000	15	15	72,5	33	27	57	55,5	16,3	64	0,28
3/4"	20	10	40	2091050000	20	16,3	81,5	39	32	57	63	29,5	64	0,39
1"	25	10	20	2091060000	25	19,1	94,5	49	38	57	66,5	43	64	0,62

## Anwendungen



DRINKING  
WATER



MULTITENANCY ONLY