

**9368**

Adapter Eurokonus-Sitz/Flachsitz.

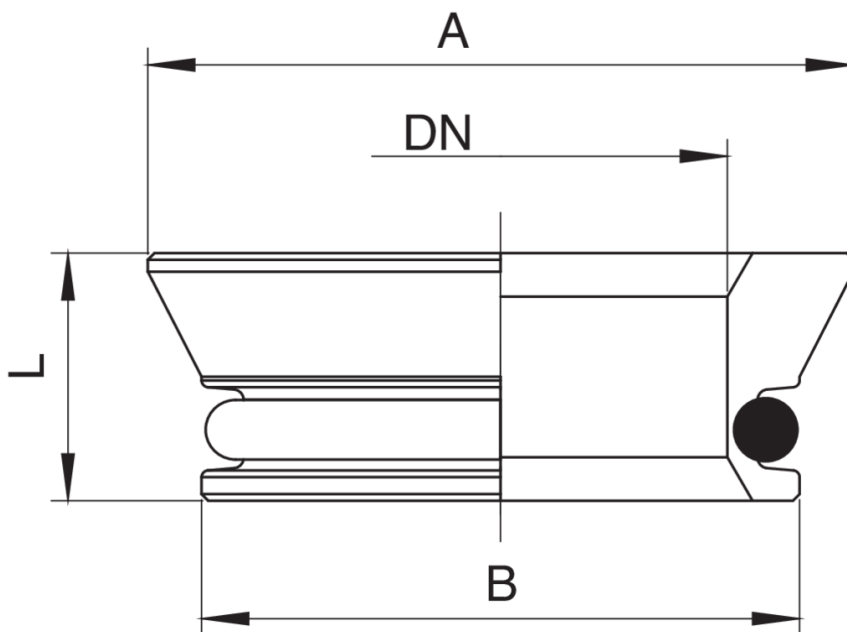

## Technische Spezifikationen



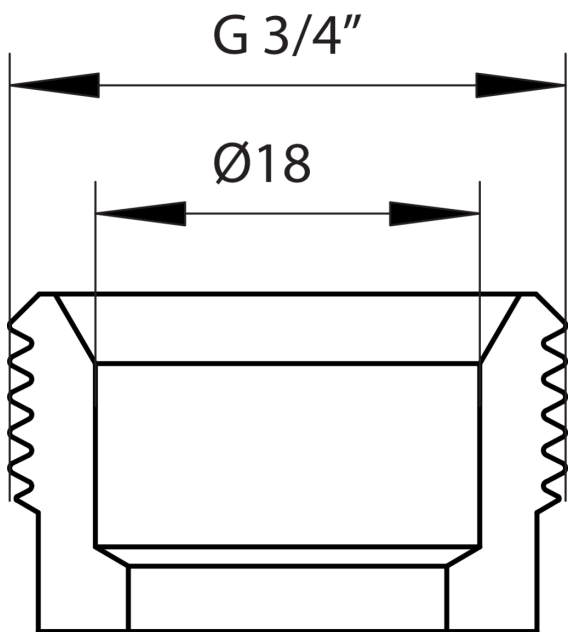

A X B	BOX	MASTER BOX	CODE	DN	L
3/4" x 18	20	160	9368050000	15	7,4

## Anwendungen



GAS