

DEVIA-SFER

5710

Verteiler drei-Wege Kugelhahn für Schalttafel,
Innengewinde, mit Griff.



Technische Spezifikationen

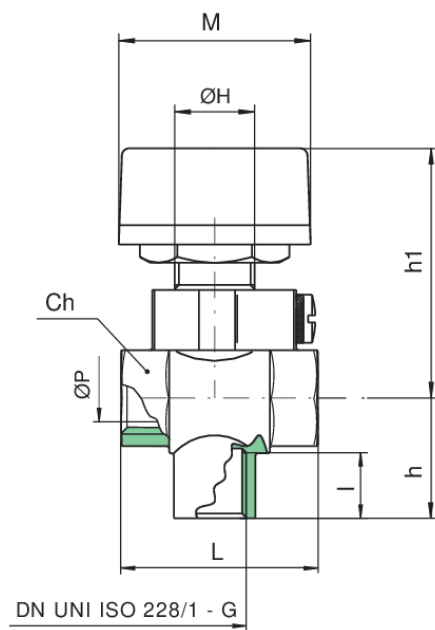
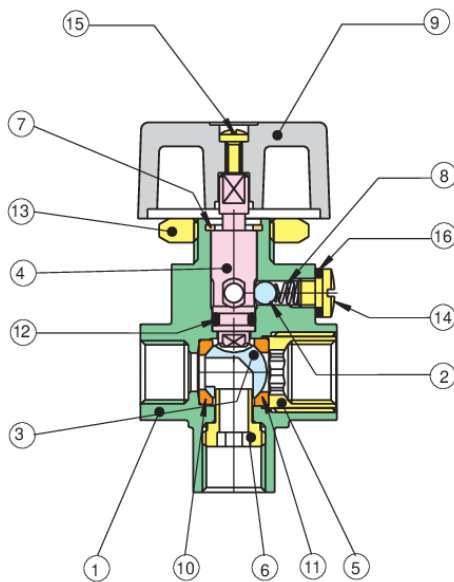

POSITION	TEILNAME	MATERIAL	NR. STÜCK
1	GEHÄUSE	BRASS CW617N UNI EN 12165	1
2	KUGEL	STAINLESS STEEL INOX AISI 430	1
3	KUGEL	BRASS CW617N UNI EN 12165	1
4	SPINDEL	BRASS CW614N UNI EN 12164	1
5	VORSPANNRING	BRASS CW614N UNI EN 12164	1
6	VORSPANNRING	BRASS CW617N UNI EN 12165	1
7	SEEGER	STAINLESS STEEL AISI 302	1
8	FEDER	STAINLESS STEEL AISI 302	1
9	ASPERRORGAN	ABS	1
10	KUGELDICHTUNG	PTFE	1
11	KUGELDICHTUNG	PTFE	1
12	O-RING	FKM	1
13	MUTTER	BRASS CW617N UNI EN 12165	1
14	SCHRAUBE	BRASS CW614N UNI EN 12164	1
15	SCHRAUBE	STEEL DD11 UNI EN 10111	1
16	SCHEIBE	STEEL DD11 UNI EN 10111	1

GRÖSSE	DN	BOX	MASTER BOX	CODE	ØP	I	CH	ØH	M	L	H	H1	KV	PN	KG
1/4"	8	20	80	5710020000	8	10	20	17	40	41	25	52	2,2	10	0,20

Temperature range: -10°C +90°C.

Anwendungen



DRINKING
WATER



HEATING



HVAC



COMPRESSED
AIR



INDUSTRIAL



MARINE