

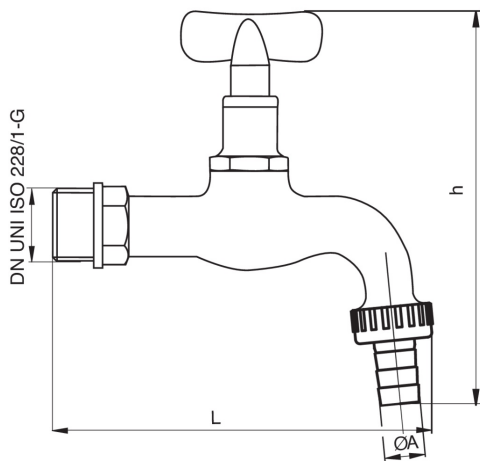

4974

Auslaufkugelhahn, verchromt, mit Schlauchtülle und mit lösbarem Schlüssel.

Technische Spezifikationen



L	H	ØA	KV	PN	KG
122	133	15,5	5,6	10	0,20

Anwendungen



DRINKING
WATER



HEATING



HVAC



COMPRESSED
AIR



INDUSTRIAL



MARINE