

4941

Auslaufkugelhahn, verchromt, mit Anschluss für Schlauchtülle, verchromter Griff und Stahlrosette.

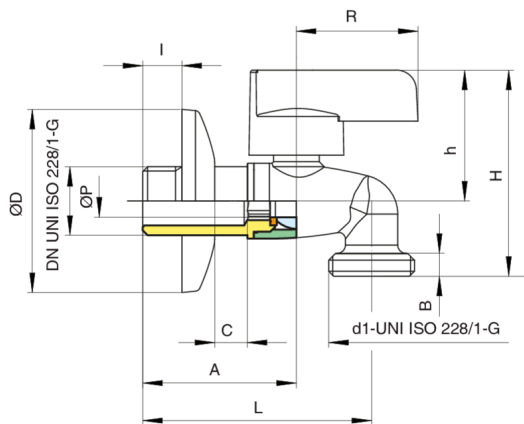

Technische Spezifikationen



GRÖSSE	DN	BOX	MASTER BOX	CODE	D1	ØP	I	L	H	H	R	A	B	ØD	C	PN	KG
1/2"	15	20	40	4941040000	3/4	10	12	70	63	40	37,2	47	7	56	-	30	0,18

Temperature range: -20°C +90°C.
Maximum depth 10 mm.

Anwendungen



DRINKING WATER



HEATING



HVAC



COMPRESSED AIR



INDUSTRIAL



MARINE