

4914

Auslaufkugelhahn mit Schlauchtülle und abschliesbarem Griff.

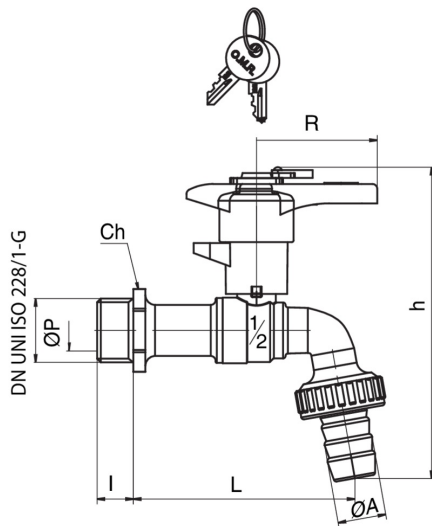

Technische Spezifikationen



GRÖSSE	DN	BOX	MASTER BOX	CODE	ØP	I	CH	L	ØA	H	R	PN	KG
1/2"	15	10	40	4914040005	10	12	25	80	15,5	116,5	50	30	0,28

Temperature range: -20°C +90°C.

Anwendungen



DRINKING WATER



HEATING



HVAC



COMPRESSED AIR



INDUSTRIAL



MARINE