

6623

Kugelhahn für Wärmezähler mit Außengewinde, Teleskopverschraubung und schwarzer Flügelgriff.

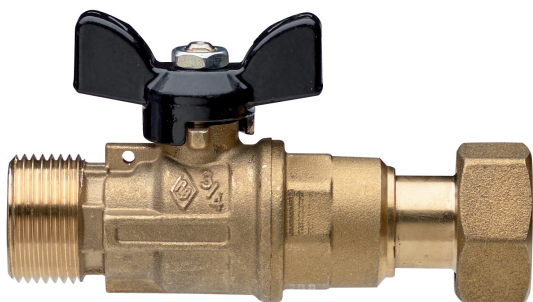

Technische Spezifikationen

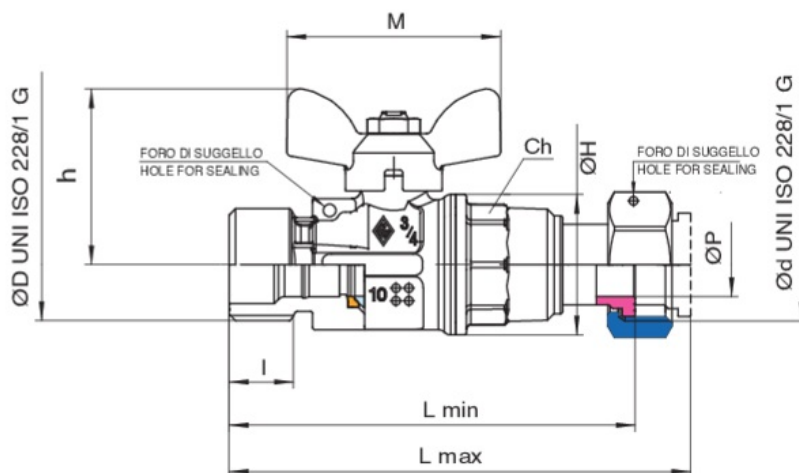
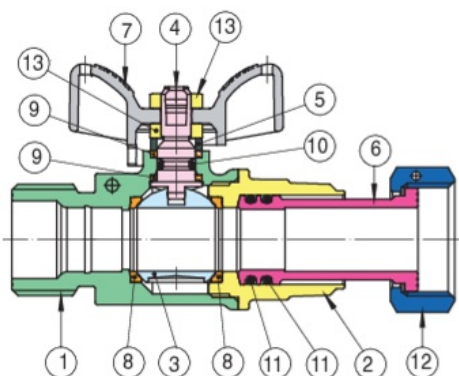

POSITION	TEILNAME	MATERIAL	NR. STÜCK
1	GEHÄUSE	BRASS CW617N UNI EN 12420	1
2	MUFFE	BRASS CW617N UNI EN 12165	1
3	KUGEL	BRASS CW617N UNI EN 12165	1
4	SPINDEL	BRASS CW614N UNI EN 12164	1
5	VORSPANNRING	BRASS CW614N UNI EN 12164	1
6	ANSCHLUSS	BRASS CW614N UNI EN 12164	1
7	GRIFF	ALUMINIUM EN-AC 46100 EN 1706	1
8	KUGELDICHUNG	PTFE	2
9	SPINDELDICHUNG	PTFE	2
10	O-RING	EPDM	1
11	O-RING	EPDM PEROX	2
12	MUTTER	BRASS CW617N UNI EN 12420	1
13	MUTTER	STEEL CL 04	2

GRÖSSE	DN	BOX	MASTER BOX	CODE	ØP	I	CH	ØH	L MIN	L MAX	H	M	KV	PN	KG
3/4" x 3/4"	20	10	20	6623050000	15	15	27	33	95	108	41	50	16,3	16	0,31
1" x 1"	25	20	40	6623060000	20	15,5	34	39	101	117	45	57	29,5	16	0,49

Temperature range: -20°C +140°C.

Anwendungen



DRINKING
WATER



HEATING



HVAC



COMPRESSED
AIR



INDUSTRIAL



MARINE