

4627

Eck-Kugelhahn mit vollem Durchgang, IG/AG mit Aluminium Flügelgriff.

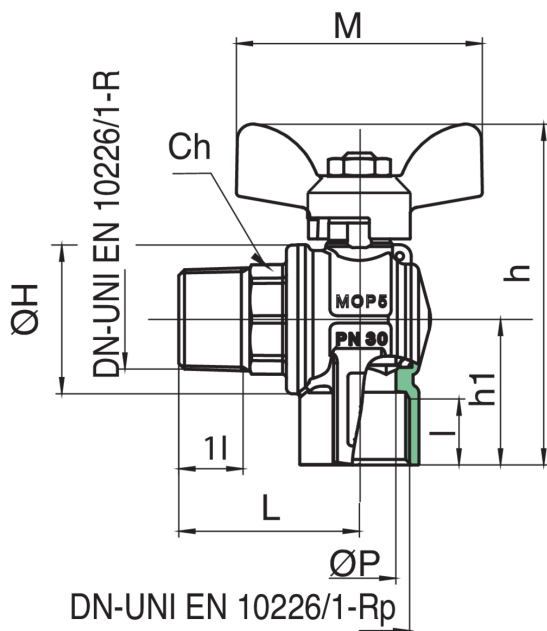

Technische Spezifikationen



GRÖSSE	DN	BOX	MASTER BOX	CODE	ØP	l1	CH	ØH	L	H	H1	M	KV	PN	KG
1/2"	15	20	80	4627040000	15	15	22	33	41,5	74,5	34	50	5,25	40	0,23
3/4"	20	10	40	4627050000	20	16,3	27	39	48,5	88,5	38	64	9,76	40	0,33
1"	25	10	20	4627060000	25	19,1	34	49	55	100	45,5	64	13,34	40	0,55

Temperature range: -20°C +160°C.

Anwendungen



DRINKING WATER



HEATING



HVAC



COMPRESSED AIR



INDUSTRIAL



MARINE