

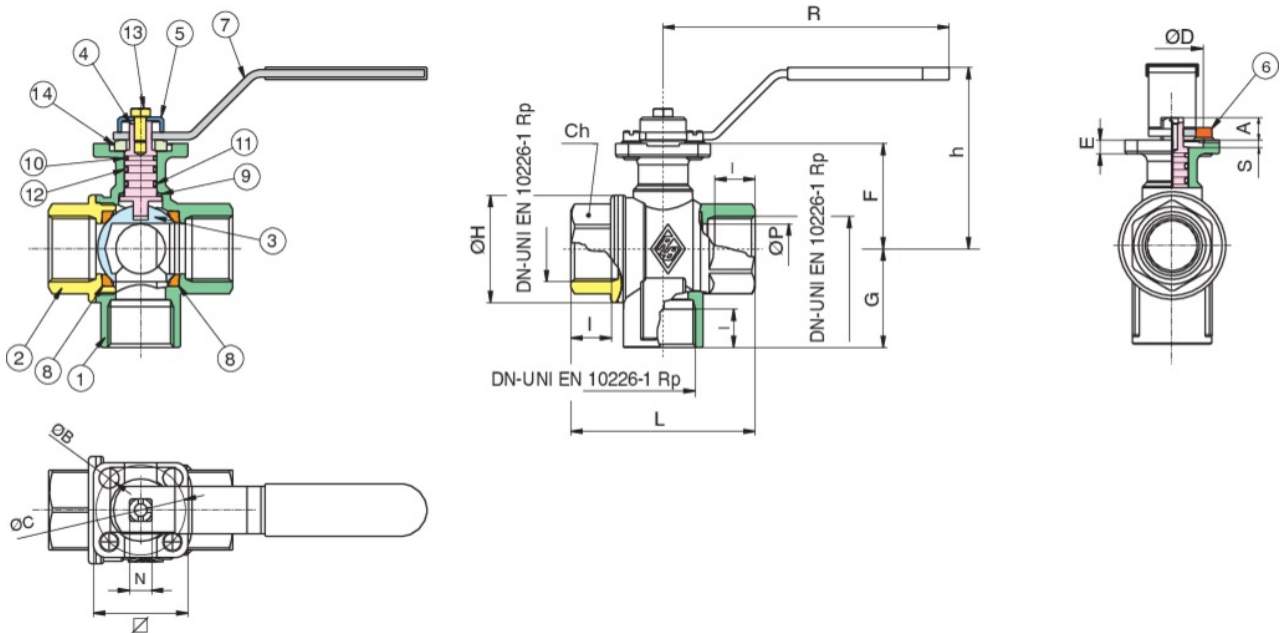

3110 T

Verteiler drei-Wege Kugelhahn, voller Durchgang, Innengewinde, T-Bohrung, mit Stahlhebeband ISO 5211 Platte für Drehantrieb.

Technische Spezifikationen



POSITION	TEILNAME	MATERIAL	NR. STÜCK
1	GEHÄUSE	BRASS CW617N UNI EN 12165	1
2	MUFFE	BRASS CW617N UNI EN 12165	1
3	KUGEL	BRASS CW617N UNI EN 12165	1
4	SPINDEL	BRASS CW614N UNI EN 12164	1
5	BUCHSE	BRASS CW614N UNI EN 12164	1
6	ANSCHLAGSTIFT	BRASS CW614N UNI EN 12164	2
7	HANDHEBEL	STEEL DD11 UNI EN 10111	1
8	KUGELDICHTUNG	PTFE	2
9	STOßHEMMENDE DICHTUNG	PTFE	1
10	STOßHEMMENDE DICHTUNG	PTFE	1
11	O-RING	FKM	2
12	O-RING	EPDM	2
13	SCHRAUBE	STEEL	1
14	UNTERLEGSCHLEIBE	PA6	1

GRÖSSE	DN	BOX	MASTER BOX	CODE	ØP	I	CH	A	ØB	ØC	ØD	S	SQUARE	E	F	G	N	ØH	L	H	R	KV	PN	KG
1/4"	8	20	40	3110020000	10	11	22	7	M7	F03 36	25	2	38	5,5	28,5	26	9	28	52	60	115	1,5	25	0,34
3/8"	10	20	40	3110030000	10	11,4	22	7	M7	F03 36	25	2	38	5,5	28,5	26	9	28	52	60	115	1,8	25	0,31
1/2"	15	20	40	3110040000	15	15	27	9	M7	F03 36	25	2	38	6	31	33,5	9	34,5	64	62	115	3,9	25	0,42
3/4"	20	15	30	3110050000	20	16,3	32	9	M7	F03 36	25	3	38	6	42	39,5	9	43	74	73	115	7,9	16	0,57
1"	25	10	20	3110060000	25	19,1	41	9	M7	F03 36	25	3	38	6,5	45	47	9	53	89	76	115	13	16	0,85
1 1/4"	32	6	12	3110070000	32	21,4	50	9	M7	F03 36	25	3	38	6	49	54,5	9	63	100	79,5	115	20,7	10	1,19
1 1/2"	40	4	8	3110080000	40	21,4	55	11	7	F05 50	35	3	50	8	61,5	61,5	11	77	110	95	170	38,7	10	1,82
2"	50	2	4	3110100000	50	25,7	70	11	7	F05 50	35	3	50	8,5	67	73	11	93	130	101	170	54	10	2,86
3**	80	0	2	3110140000	80	33,3	105	-	-	-	-	-	-	-	-	106	20	148	197	150	260	145,7	6	9,01

Temperature range: -15°C +120°C.

*Without ISO 5211 pad.

Anwendungen



DRINKING
WATER



HEATING



HVAC



COMPRESSED
AIR



INDUSTRIAL



MARINE