

Technische Spezifikationen

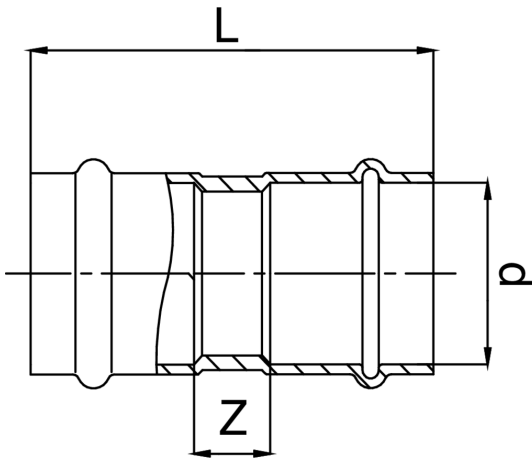

D	BAG	MASTER BOX	CODE	L	Z
15	10	150	ZX0270015015000	57	13
18	10	100	ZX0270018018000	71	23
22	5	70	ZX0270022022000	71	23
28	5	40	ZX0270028028000	80	30
35	5	35	ZX0270035035000	84	23
42	1	25	ZX0270042042000	97	25
54	1	15	ZX0270054054000	107	27

Anwendungen



DRINKING
WATER



HEATING



HVAC



COMPRESSED
AIR



FIREFIGHTING



MARINE



STEAM



SOLAR



INDUSTRIAL