



# 310410

Kugelhahn SUPERFILTER mit eingebautem Filter 500 µm und Magnet.  
Gewinde i/i UNI ISO 228/1, Hebel aus Stahl.

**NEW**

## Technische Spezifikationen

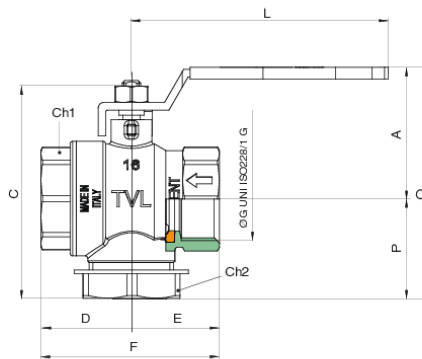
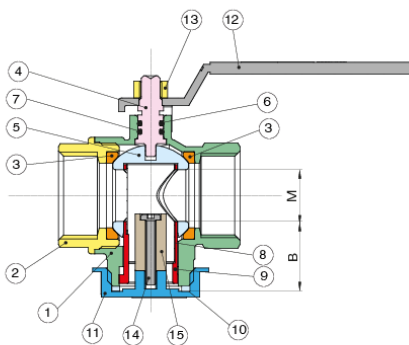

POSITION	TEILNAME	MATERIAL	NR. STÜCK
1	GEHÄUSE	BRASS CW617N UNI EN 12165	1
2	MUFFE	BRASS CW617N UNI EN 12165	1
3	KUGELDICHTUNG	PTFE	2
4	SPINDEL	BRASS CW614 UNI EN 12164	1
5	KUGEL	BRASS CW617N UNI EN 12165 CROMATO	1
6	O-RING	NBR	1
7	O-RING	FKM	1
8-9	SCHMUTZFÄNGER	AISI 304+Nylon	1
10	FALCHE DICHTUNG	NBR	1
11	SIEBTASSE	BRASS CW614 UNI EN 12164	1
12	HANDHEBEL	ZINC PLATED STEEL	1
13	MUTTER	ZINC PLATED STEEL	1
14	SCHRAUBE	INOX	1
15	MAGNET	NEODIMIO (12.000 GAUSS) NDFEB	1

A	B	C	D	E	F	L	O	P	CH1	CH2	PN
47,4	30,9	73,58	29	32,3	61,3	100	82,5	35,1	31	30	30
50,8	34,5	80,5	34,5	35,6	70,1	100	89,5	38,7	38	38	30
74	46,5	106	40	45	85	158	125,5	51,5	48	46	20
80	52,5	118	45,5	52	97,5	158	137,5	57,5	54	55	20
88,5	63,5	143	54	63	117	158	157	68,5	66	65	20