

**588700**

Anschlussverschraubung lang AG mit Schnellkupplung patentierten.



**NEW**

## Technische Spezifikationen

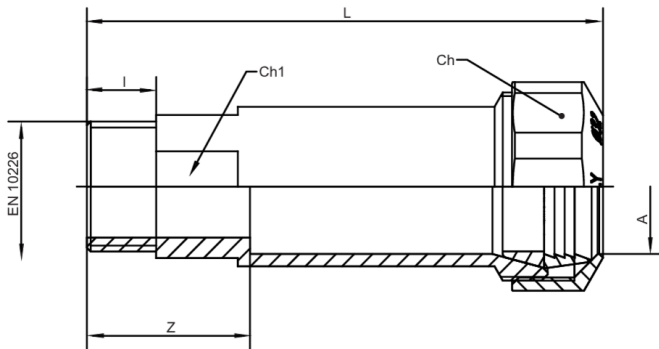

A X B	BOX	MASTER BOX	CODE	I	CH	CH1	L	Z
25 x 3/4"	15	60	5887002505	15	41	28	100	45
32 x 1"	8	32	5887003206	17	51	35	123	40
40 x 1 1/4	5	20	5887004007	18,5	59	44	123	40
50 x 1 1/2	2	8	5887005008	19	70	54	123	40
63 x 2"	2	8	5887006310	22	87	68	123	48

## Anwendungen

