

580500

Schiebemuffe mit Klemmring aus Schnellkupplung patentierten.



NEW

Technische Spezifikationen

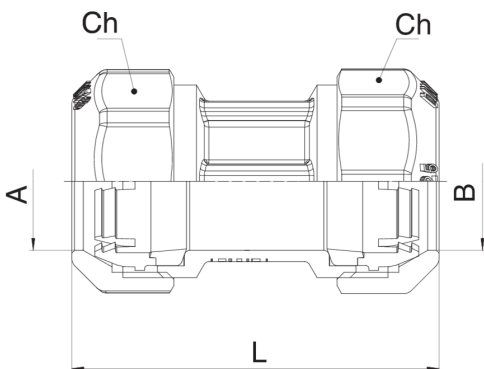

A X B	BOX	MASTER BOX	CODE	L	CH
25 x 25	16	64	58050025	91	41
32 x 32	8	32	58050032	100	51
40 x 40	4	16	58050040	111	59
50 x 50	4	16	58050050	114,5	70
63 x 63	4	16	58050063	137,5	87

Anwendungen

