

2091 QB

Kugelhahn, Zählereinlass, voller Durchgang, A/I Anschlüsse, unidirektional, manipulationssicherer Flügelgriff und **Edelstahl-Sicherheitsmutter**, ausgestattet mit Vitalsystem und Kugel mit automatischem Spülsystem.

NEW



Technische Spezifikationen

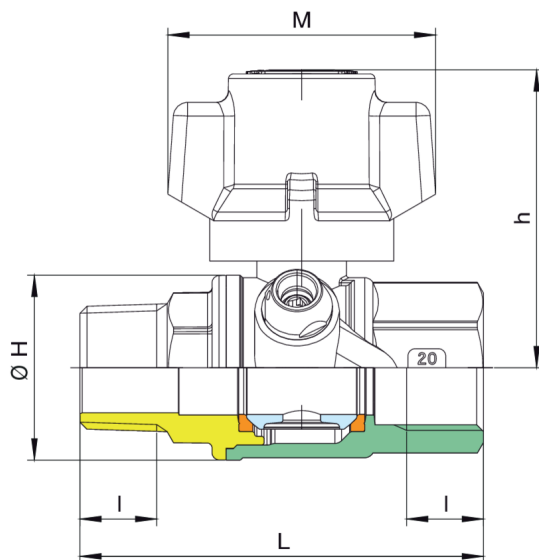

GRÖSSE	DN	BOX	MASTER BOX	CODE	MINIMUM VITAL (L/GG)	ØP	I	L	ØH	CH	M	A	H	KV	PN	KG
1/2"	15	15	60	2091040151*	150	15	15	75	33	27	57	38,5	55,5	16	64	0,33
1/2"	15	15	60	2091040301*	300	15	15	75	33	27	57	38,5	55,5	16	64	0,33
1/2"	15	15	60	2091040601*	600	15	15	75	33	27	57	38,5	55,5	16	64	0,33
3/4"	20	10	40	2091050151*	150	20	16,3	88,5	39	32	57	40,5	63	29	64	0,46
3/4"	20	10	40	2091050301*	300	20	16,3	88,5	39	32	57	40,5	63	29	64	0,46
3/4"	20	10	40	2091050601*	600	20	16,3	88,5	39	32	57	40,5	63	29	64	0,46
1"	25	10	20	2091060151*	150	25	19,1	96,5	49	38	57	43,5	66,5	42,5	64	0,65
1"	25	10	20	2091060301*	300	25	19,1	96,5	49	38	57	43,5	66,5	42,5	64	0,65
1"	25	10	20	2091060601*	600	25	19,1	96,5	49	38	57	43,5	66,5	42,5	64	0,65

*Version with heptagonal-shaped stainless steel security nut.

Anwendungen



DRINKING
WATER



MULTIUTILITY ONLY