

Technische Spezifikationen

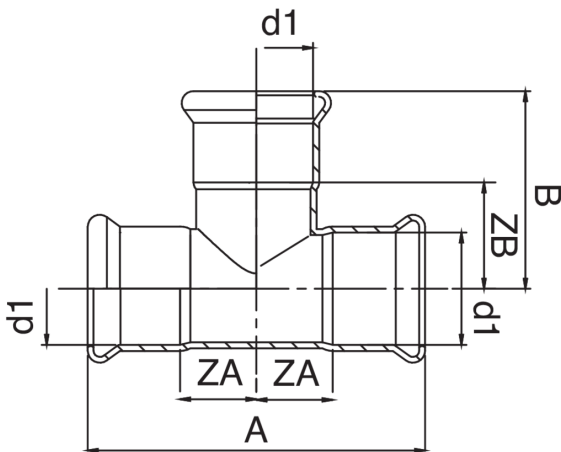

D1	BAG	MASTER BOX	CODE	A	B	ZA	ZB
76,1*	1	5	AX0130076076076	242	121,5	66	66,5
88,9*	1	3	AX0130089089089	272	133	76	73
108*	1	1	AX0130108108108	324	165	92	95

Anwendungen



DRINKING
WATER



HEATING



HVAC



COMPRESSED
AIR



FIREFIGHTING



MARINE



STEAM



SOLAR



INDUSTRIAL